

DIRECTION 324

BAR MOUNT DETAIL

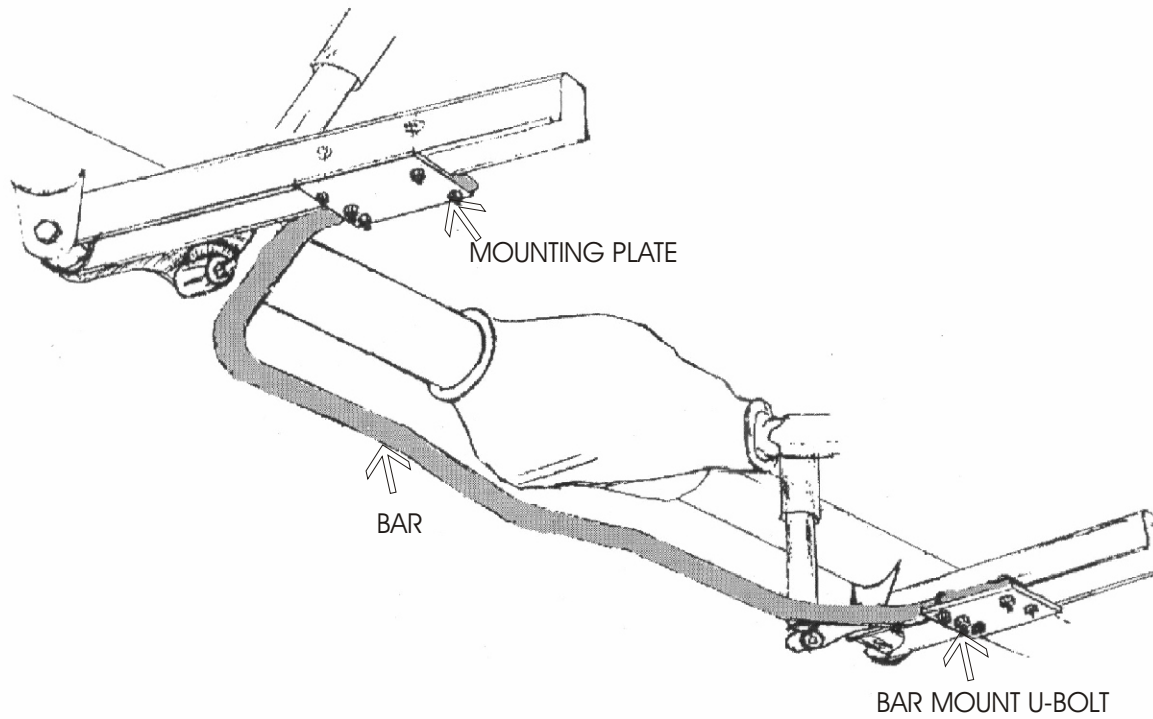
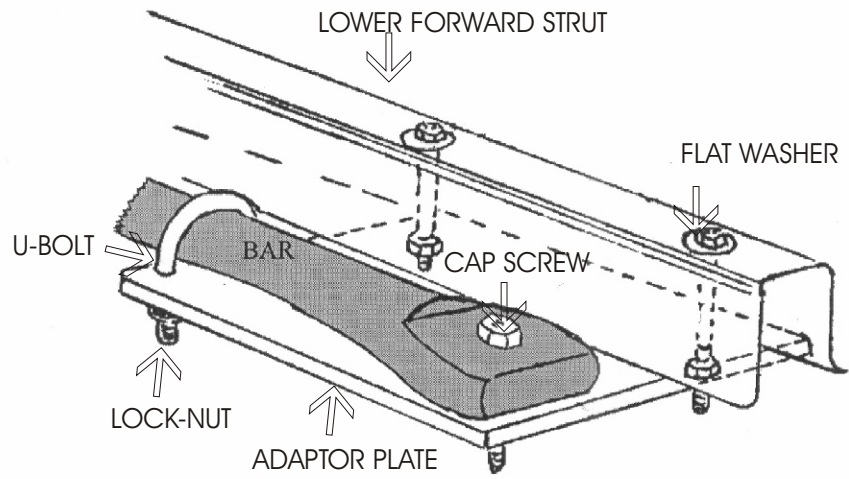

DIRECTIONS 324

- STEP #1.** **Attach the sway bar to the reinforcing plates using the short bolts and the U-bolts. The U-bolts may need to be bent slightly to fit the plates. This should be checked first for ease of assembly.**
- STEP #2.** **With the plates attached to the bar it should be held up under the car in position. The outer bend should be just forward of the shock absorber on the later models, and on the older models, the shock absorber is behind the axle. Be sure that the bar is just enough to the rear that it will not be struck by the tailpipe.**
- STEP #3.** **With the bar in position against the bottom of the lower suspension strut, mark it for drilling.**
- STEP #4.** **Drill the strut with a 3/8" bit and bolt the sway bar on. The dip should be down.**
- STEP #5.** **Have someone bounce the rear of the car while you check the clearance of all parts throughout the suspension travel distance. Tighten all of the nuts.**
- STEP #6.** **Road test the car and familiarize yourself with your car's greatly improved handling characteristics. As we cannot supervise your installation, or your driving, we cannot be held responsible for more than the cost of the kit.**

HARDWARE

2 RH 213 Bolts	10 RH 304 Lock-nuts
4 RH 205 Bolts	2 RH 400 U-Bolts
4 RH 102 Washers	2 RH 037 Plates