



INSTALLATION INSTRUCTIONS

INSTALLATION INSTRUCTIONS FOR
A136 REAR DRUM TO DISC BRAKE CONVERSION KIT
for 1970-75 Jeep, CJ SERIES with Dana 44 flanged axle

Thank you for choosing STAINLESS STEEL BRAKES CORPORATION for your braking needs. Please take the time to read and carefully follow these instructions to insure the ease of your installation as well as the proper performance of the complete system.

Before beginning your installation, please verify you have received all the parts indicated on the packing slip. If you believe anything to be missing or incorrect, please call our Customer Service Department at 716-759-8666.

To assure your installation will go safely and smoothly, have the following items on hand to assist you:

JACK & JACK STANDS
LUG WRENCH
TORQUE WRENCH
SOCKET SET
WRENCH SET

TUBE WRENCHES
BRAKE CLEANER
WHEEL BEARING GREASE
BRAKE FLUID
2-1/16" HUB SOCKET



IN ORDER TO COMPLETE THIS INSTALLATION IT WILL BE NECESSARY TO REDUCE THE DIAMETER OF THE AXLE FLANGE, REMOVE THE REAR AXLE BEARING FROM THE AXLE SHAFT USING A PRESS AND REPLACE THE ORIGINAL LUG STUDS WITH THE NEW STUDS SUPPLIED. FURTHER, WE STRONGLY RECOMMEND THAT THIS CONVERSION ONLY BE FITTED IF THE FRONT AXLE OF THE VEHICLE IS ALSO EQUIPPED WITH DISC BRAKES.

- 1) Raise the Jeep until the wheels and tires clear the floor. Support Jeep on jack stands. Remove the wheel cover or hub cap. Remove wheel and tire assembly from the drum.
- 2) Remove drum brake assembly as follows:
 - a) Pull off brake drum from assembly.



IF THE BRAKE DRUM WILL NOT COME OFF EASILY, RETRACT SHOES BY INSERTING A NARROW SCREWDRIVER (OR SPECIAL TOOL) THROUGH THE BRAKE ADJUSTING SLOT IN THE BACKING PLATE, AND DISENGAGE THE ADJUSTING LEVER FROM THE ADJUSTING SCREW. WHILE THUS HOLDING THE ADJUSTING SCREW, BACK OFF THREAD ADJUSTING TOOL.

- b) Remove brake drum from axle.
 - c) Disconnect parking brake cable from actuator and pull through backing plate after compressing retaining clip.
 - d) Disconnect rigid brake lines from back of wheel cylinder and discard.
- 3) Remove axle and backing plate assembly as follows:
 - a) Remove nuts and bolts holding the backing plate to the axle flange (it may be necessary on some axles to first pry out axle flange cup plug to attain access to hole in flange).
 - b) Pull out axle shaft carefully, so as not to damage shaft seal mounted in the axle housing (it may be necessary to use an axle puller).
- 4) Axle:



REWORK IS REQUIRED BEFORE REINSTALLATION OF AXLE.

- a) Remove locking ring and bearing from axle shaft. (This operation will require the use of a special fixture and a press).
- b) Remove backing plate and shoe assembly as a unit from axle housing and discard.
- c) Machine outside diameter of axle flange to 6.60" dia. max.
- d) While axle is out of housing, press lug studs out of flange; discard. This can be done by supporting axle in a vise and hammering out studs.(use a brass hammer)
- e) After machining flange, install new lug studs (from kit) in the reverse of above. Stud heads need not to be bottomed in flange since this will be accomplished when wheel is first tightened.

- 5) Axle shaft reassembly
- a) Press new axle grease seals into caliper mounting bracket. Install one grease seal from one side of one plate and one seal from other side of other plate (base mounting brackets are identical and may be used on either side).
 - b) Slide caliper mounting plates (with installed seal) over axle shaft (before reinstalling axle bearing). Be sure that the grease seal lips face the inside or splined end of the axle.



CALIPER MOUNTING PLATES ARE LOCATED IN THE SAME POSITION ON THE AXLE SHAFT AS WERE THE DRUM BRAKE BACKING PLATES. REUSE ORIGINAL RETAINER PLATES.

- c) Assemble axle bearing/locking ring and split shim (from kit) in sequence on axle.
- d) Reinstall axle assembly into housing and secure base plate to axle housing flange with (4) $\frac{3}{8}$ -24 x 1- $\frac{1}{4}$ " bolts (hex heads on the outside) and elastic stop nuts. Torque to 40 ft.-lbs.



MAKE SURE THAT CALIPER MOUNTING PLATE IS AT (APPROXIMATELY) 45° ANGLE WITH UPPER PORTION OF PLATE TOWARD SHOCK ABSORBER (BOTH SIDES). SEE ATTACHED ASSEMBLY SHEET!

- e) The assembly of the caliper mounting bracket is completed using four $\frac{7}{16}$ -20 x 1- $\frac{1}{2}$ " bolts (from kit) installed through the four (4) outer holes of the base plate (hex head on the outside).
 - f) The sequence of parts on the above bolts are as follows:
 - 1) Splash shield (round section toward shock absorber and turned edges to outside).
 - 2) Mounting plate.
 - 3) Four $\frac{7}{16}$ " i.d. x $\frac{3}{8}$ " thick tubular spacers (one over each bolt).
 - 4) Caliper mounting brackets (boomerang shaped, longer leg on rear lower side of mounting plate, with angled legs facing up, shorter leg bracket at opposite end, facing down).
 - 5) Parking brake bracket (center hole of longer leg) onto upper front bolt.
 - g) Secure assembly with (4) $\frac{7}{16}$ -20 elastic stop nuts and torque four fasteners 65-70 ft.-lbs.
- 6) Rotors:
- a) The axle center pilot should be 4- $\frac{1}{4}$ " and the rotor should fit against the axle flange. Mount rotor on axle and temporarily secure with at least one lug nut.

- 7) Caliper assembly and mounting:



DO NOT USE ANTI-SQUEAK ADHESIVE ON BACKS OF BRAKE PADS. THIS WILL DEGRADE THE PERFORMANCE OF THE CALIPER!

- a) Push (2) 12mm-1 special caliper mounting bolts (loctite spot on threads) into

mounting bracket holes (hex heads on inside), slide 1/2" i.d. x 3/8" thick tubular spacer over bolts and then screw into caliper mounting ears. Torque bolts to 80-110 ft-lbs.



CALIPERS ARE MARKED LEFT AND RIGHT, LEFT IS DRIVER SIDE. WHEN MOUNTING CALIPERS MAKE SURE THAT PARKING BRAKE LEVERS ARE TOWARD FRONT.

- 8) Brake lines
- a) Install flex hoses, from kit, with brass "banjo" blocks. Orient blocks and hoses so that they point toward center of axle housing. Attach blocks to caliper inlet ports using special hollow bolt and 1 copper washer on each side of block. Torque bolt to 20-30 ft-lbs.
 - b) Obtain left hand axle brake line and connect to left flex line and original axle distribution block. Install short line from block to right flex line and secure. Use at least two wrenches; one, a tube wrench.



MAKE SURE THAT FLEX LINES TAKE A SMOOTH BEND AND ARE NOT "KINKED" WHEN FINAL CONNECTION IS MADE.

- c) Secure brake lines to axle housing using original clips and/or "tie-wraps."
- 9) Parking brake cable:
- a) Feed parking brake cable through ("L" shaped) support bracket and assure that housing clip engages and locks into bracket. Compress spring and engage cable end into parking brake lever.
 - b) Do not attempt to adjust parking brake at this time; wait until system is filled and bled.
- 10) Filling and Bleeding the System:



BE CAREFUL THAT ALL HYDRAULIC COMPONENTS ARE KEPT CLEAN AND FREE OF DEBRIS INSIDE AND OUT. REMEMBER: DIRT IS THE ENEMY OF HYDRAULIC SYSTEMS, AND WE WILL NOT BE RESPONSIBLE FOR SYSTEM FAILURES DUE TO UNCLEAN INSTALLATION!

- a) It is advisable to replace brake fluid if the color is brown and muddy. This condition is due to water that has been absorbed by the fluid which will eventually corrode the brake lines and master cylinder, plus possibly creating a vapor lock under extreme braking conditions. Flush system with clean brake fluid and replace with a good grade of disc brake fluid (DOT 3 or 4 Glycol base) or with Silicone Brake Fluid (DOT 5) available from SSBC or your distributor. This fluid will not absorb water, does not damage paint and maintains its viscosity over a large temperature range.
- b) If pressure bleeding is employed the air pressure regulator setting is 10-15 psi.(max.)
- c) Tapping the caliper with a rawhide mallet before fluid is flowing out may assist in obtaining a better bleed job.
- d) Brake bleeding can be simplified and at the same time assure that there are no line restrictions by using the gravity bleeding method, as follows:

- 1) Leave bleeder screws open when installing calipers.
- 2) Fill master cylinder reservoir, do not pressurize master cylinder or pump brake pedal; instead observe bleeder ports until brake fluid flows out; then shut off the bleeders.
- 3) No further procedure is required if brake pedal is hard after shutting off all bleeders. Make sure that master cylinder is "topped-off."
 - a) With bleeders closed and system bled, a hard pedal should be experienced so that at full application the toe of your left foot can still be placed between the bottom of the pedal and the floor.
 - 1) In addition there should be brake pedal end-play of $\frac{7}{8}$ " to 1 inch (from full release until initial braking action takes place).
 - 2) Pedal end-play should be adjusted by lengthening or shortening the push rod between the pedal rod. This is the best accomplished from under the dash.

11) Parking brake adjustment:

- a) Advance pistons of calipers so that clearance between pads and rotors is $\frac{1}{32}$ - $\frac{1}{16}$ ". Piston should be advanced using hydraulic system, instead of parking brake levers. Several pumps of the pedal may be required to extend the pistons to the correct clearance.



IF PISTON HAS BEEN EXTENDED TOO FAR, SCREW PISTON BACK INTO CALIPER; USE SPECIAL TOOL KD-2545, AVAILABLE AT MOST PARTS STORES OR A STRONG PAIR OF NEEDLE NOSE PLIERS.

- b) Make sure that the parking brake lever is in the released position (press down handle towards floor as far as possible).
- c) Take up slack in cables by adjusting the nut on the threaded rod under truck.
- d) Test several times to assure that operation is normal and that the truck can't roll when the brake is applied but does not drag in the released position.

12) Final Assembly:

- a) Take lug nuts off studs.
- b) Mount wheel, torque lug nuts to proper specifications.
- c) Spin wheel to assure that there are no interferences.
- d) Lower Jeep to ground.



TURN WHEEL BY HAND AND CHECK FOR ANY INTERFERENCES. DO NOT DRIVE THE JEEP UNTIL BRAKES STOP WITHOUT A SPONGY FEELING PEDAL. INITIAL BRAKING TESTS SHOULD BE DONE IN A SAFE OPEN AREA. IF THE BRAKES DO NOT OPERATE CORRECTLY, CONTACT ONE OF OUR TECHNICIANS FOR ASSISTANCE.

- e) Test drive and apply brakes frequently to seat pads.

TECH LINE -- If technical help is required, please call 716-759-8666.

NOW ENJOY TRUE PERFORMANCE BRAKING!!



Stainless Steel Brakes Corporation
 11470 Main Road
 Clarence, NY 14031
 (716) 759-8896
 Fax: (716) 759-8888
 www.ssbbrakes.com
 tech@ssbrakes.com

A136

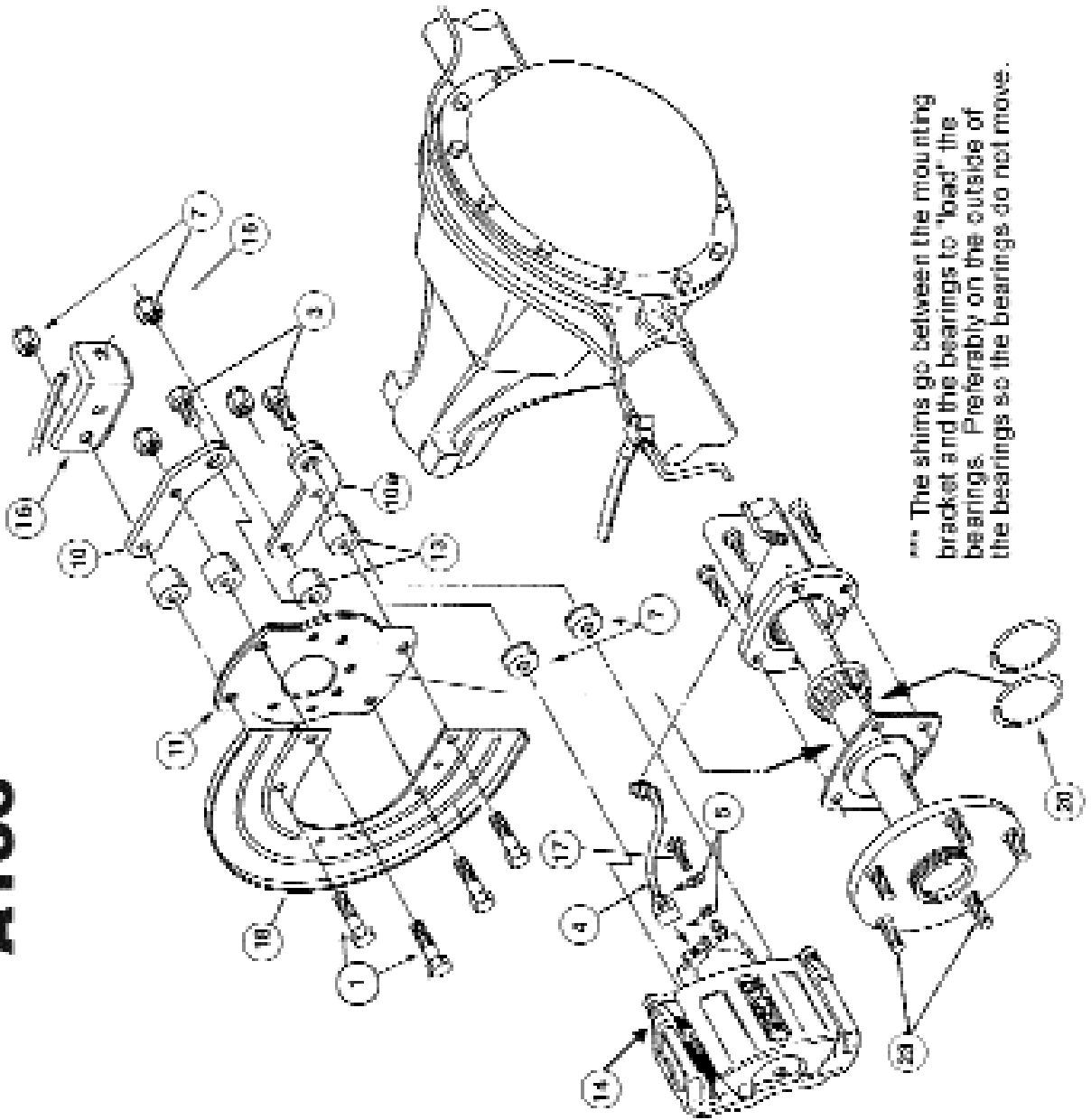

*** The shims go between the mounting bracket and the bearings to "load" the bearings. Preferably on the outside of the bearings so the bearings do not move.

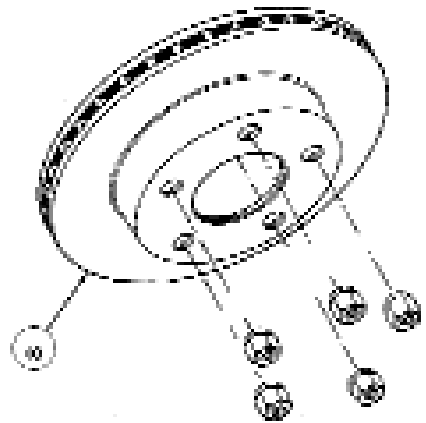

Solutions Guide

to commonly asked questions.

Why is my brake pedal soft?

1) In most cases, Air is trapped in the lines or calipers. Try re-bleeding the system. Do not force new fluid into new brake lines. It may foam and be very difficult to bleed. **Make sure that the bleeder screws on the calipers are facing upward!**

2) If all the air is out of the system, the pushrod from the booster may need adjustment, under the dash, to make it longer. Do not extend it too long or it will not allow the fluid to return, causing brakes to drag. Your pushrod may not be adjustable. If the pushrod can be made longer, try ¼ turn adjustments at a time. SSBC stocks adjustable pushrods for many vehicles. In addition, the pushrod between the Booster and the Master Cylinder may need adjustment. Not all Booster to Master pushrods are adjustable.

3) You may have a bad Master Cylinder. Before you determine this, you should make sure that all the air is out of the system. When installing a new Master Cylinder, always bench bleed first. If you did not, take off the Master Cylinder and bench bleed it. (See Bench Bleeding Instructions below)

Why does the car pull to one side?

The side that the car is pulling to is the caliper that is working. Re-bleed the opposite side and try carefully stopping again.

Why does it feel like there is no Power Assist?

The Booster may not be getting enough vacuum to operate. On some high lift cams, the engine does not develop enough vacuum. The Booster needs at least 16" of vacuum to operate correctly at idle. If you do not have at least 16 inches of vacuum at idle, you may have to add a vacuum pump to your system.

Check for vacuum leaks. There may be leaks in the intake manifold or hoses that would cause low vacuum. The Booster may be bad. Do a vacuum test. If the Booster can retain a vacuum for three (3) minutes after the vehicle is shut off, it is not a bad Booster (refer to steps 1 & 2). All Master Cylinders must be bench bled in a vise before being installed on the vehicle.

How do you bench bleed a Master Cylinder?

Secure one of the ears in a vise so that you can take a large screwdriver and push the piston in. Fill the reservoir with clean fluid. Take a dummy line or our M/C bleeding kit and hook it up to the two ports. Front line to front and rear line to rear reservoirs. Slowly stroke the master and let it return slowly. You should see many air bubbles in the fluid. Repeat this step until you do not see any more air bubbles. SSBC recommends ten (10) slow pumping strokes after you see no more air bubbles. This will insure a good hard pedal. (See SSBC part #0460 Instruction Sheet)

What is the best pad for my vehicle?

Your choice of pads should be determined by how and where you drive the vehicle. If you drive in heavy stop and go traffic you would need a different pad than someone who is road racing. Contact SSBC for the correct application.

How often should brake fluid be changed? (street application only, not racing)

When brake fluid turns brown, it is time to change the fluid. The brown color indicates that the fluid has absorbed water and dirt. D.O.T. #3 & #4 fluids absorb water. Silicone brake fluid is not for track racing.

How can I tell which reservoir is the front or rear of the Master Cylinder?

The front reservoir is usually larger than the rear. In some cases, they are the same size. As a rule, for GM cars & trucks, the rear reservoir is for the rear brakes. On Ford cars & trucks, the front reservoir is for the rear brakes. On front wheel drive vehicles, the brakes are split diagonally. Each bowl of the master cylinder services one front wheel and one rear wheel. This will be important if you are installing a distribution block, proportioning valve, or residual valve. Hint: The larger bowl will feed the disc brakes.

Where is the best place to install a proportioning valve?

The best place to install a proportioning valve is after the distribution block. **Do Not install it between the Distribution Block and the Master Cylinder.** You will not be able to get a hard pedal. Anywhere after the Distribution Block and before the rear flex hose is acceptable for installation.

Why should the flex hoses be replaced? They look O.K. from the outside.

Flex hoses should be replaced every time the calipers are serviced. They flex up and down, just like a shock absorber. They are also under high pressure internally. Flex hoses have a rubber liner that will collapse over time. If it does collapse, it will act as a check valve and not allow fluid to return to the Master Cylinder.

Will my pedal get harder by replacing the flex hoses?

No. When the flex hoses are replaced, re-bleed the brake system. Normally what happens is that bleeding causes a harder brake pedal. A better bleeding job and taking your time will result in the same situation.

Are the rubber flex hoses expanding causing a soft pedal?

Not likely. A soft pedal is usually a sign of air in the system due to poor bleeding. Flex hoses have nylon webbing that is molded into the internal rubber. It is very strong and will hold up to 3,000 P.S.I. Installing braided stainless steel hoses is not necessary; it only improves appearance.

How much brake pressure does it take to stop my vehicle?

Most vehicles, power or non power brake, develop 1,200 P.S.I. When you panic stop or jump on the brakes hard, a surge of 1,400 P.S.I. can be achieved. If a factory proportioning valve installed on the vehicle, the rear brakes are only developing 600 – 700 P.S.I. Drum brakes require lower pressure because they grab more quickly. When rear disc brakes are installed, the rear brake pressure may be increased to 800 – 1,000 P.S.I. or more. A good way to check the pressures and to see if the system is working correctly, use a pressure gauge screwed into the bleeder port (SSBC part # A1704). A vehicle with less than 600 P.S.I will not stop!

How tight should the wheel bearings be?

The front bearings should always be torqued. Not just hand tightened. Bearings usually require 12-15 Ft./Lbs. of torque. Then you will probably need to back off a little to align the cotter pin hole. Do Not over tighten; the bearing life will be shortened. This procedure only applies to rear wheel drive vehicles with separate bearings and races. On vehicles with one piece sealed bearing assemblies or hub assemblies, refer to a service manual.

What type of differential fluid should I use in my rear axle?

If you have positraction, use a Hypoid or Limited Slip additive that is designed for your particular rear end. If you do not have positraction, any type of 80 –90 weight gear lube is acceptable. Fluid should be changed often if you are trailering or any type of extreme usage. This fluid does brake down with time and usage.



Stainless Steel Brakes Corporation

11470 Main Road • Clarence, NY 14031
 Ph: 716-759-8666 Fx: 716-759-8688
 ssbrakes.com • tech@ssbrakes.com

**REPLACEMENT
PARTS
ORDER FORM**

DATE: _____

CUSTOMER # (from receipt): _____

ORDERED BY:
NAME: _____
COMPANY: _____
STREET: _____
CITY: _____ **ST:** _____ **ZIP:** _____

SHIP TO:
NAME: _____
COMPANY: _____
STREET: _____
CITY: _____ **ST:** _____ **ZIP:** _____

VEHICLE INFORMATION:
TYPE OF AUTOMOBILE: _____

TYPE OF DRIVING:
 STREET RACING
 STREET & SLALOM STREET MODIFIED

ORDER INFORMATION:

QUANTITY	PART #	DESCRIPTION	UNIT PRICE	
AMOUNT				

METHOD OF PAYMENT:

CHECK/MONEY ORDER VISA MASTERCARD DISCOVER AMEX

CREDIT CARD #: _____ **EXP:** _____

SIGNATURE: _____

Total Merchandise
NY Residents Sales Tax
Ins. (add \$0.35 per \$100.00)
UPS Shipping (please call)
TOTAL

FREE FREIGHT
 IF ORDERED WITHIN 30 DAYS OF INITIAL ORDER
MAIL OR FAX YOUR ORDER!

How and why do I bench bleed a master cylinder?

When installing or replacing a master cylinder, it is critical that all air is removed from the master cylinder. This can easily be done by bench bleeding the master cylinder prior to installation. Using the SSBC master cylinder bleeder kit (#0460):

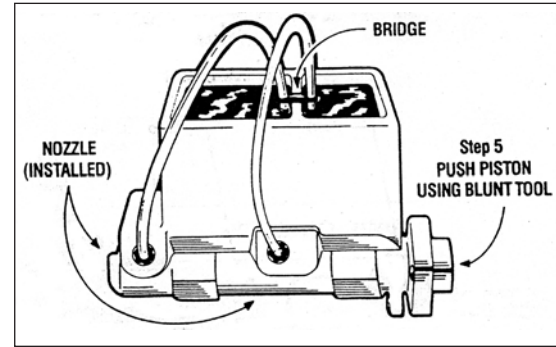

- 1) Place your master cylinder in a vise by the ears (not body). Make sure it is level.
- 2) Attach a piece of clear plastic hose to the short end of one of the plastic nozzles. Do the same to the other hose and nozzle.
- 3) Clip the plastic bridge to the wall and push the ends of the hose through the holes so they are SUBMERGED in the reservoir on either side of the wall.
- 4) Press the tapered end of the nozzle FIRMLY into the cylinder port hole with a twisting motion. Repeat this procedure on the other port hole.
- 5) Fill the reservoir with CLEAN brake fluid recommended by the manufacturer.
- 6) Using full strokes, push the piston in, then release. Do this until ALL the air bubbles have disappeared from the clear plastic hose. **(CAUTION-MASTER CYLINDER WILL NOT BLEED PROPERLY UNLESS HOSES ARE SUBMERGED IN BRAKE FLUID UNTIL THE BLEEDING PROCESS IS COMPLETED.)**

Now mount master cylinder and avoid brake fluid leaking out of front and rear ports during installation.

Bleeding steps for Dual Port Master Cylinder







If you have a master cylinder with dual port holes (4 port holes - 2 on each side), it is necessary to bleed both port sides of the master cylinder. If both sides of the master cylinder are not bled, there will be air trapped in the master cylinder and your brakes will not function properly.

To bleed dual port master cylinders:

- 1) Follow steps 1 - 6 above on the side you will be hooking the brake lines to. Plug the other side.
- 2) Once the air bubbles are no longer visible in the plastic hose, open the bleeder screws in the supplied plugs and allow the mater cylinder to gravity bleed. **DO NOT** push the master cylinder piston in while the plugs are gravity bleeding.
- 3) When clear, steady streams of fluid are coming out of both bleeders, close and tighten the bleeders. Give the master cylinder piston several strokes, making sure there are still no bubbles present in the clear plastic tubes.
- 4) Remove the tubes and plastic fittings and mount the master cylinder on the vehicle being careful not to spill brake fluid on any painted surfaces.

TORQUE SPECIFICATIONS

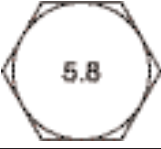
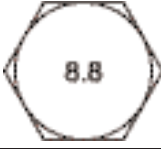
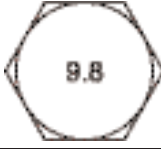
BEFORE DRIVING YOUR VEHICLE, YOU SHOULD CHECK THE TORQUE ON ALL NUTS AND BOLTS IN THE KIT, INCLUDING ANY SLIDER BOLTS ON THE CALIPERS. RE-TORQUE CALIPER BOLTS AFTER 500 MILES. ALL SPECIFICATIONS ARE IN FT-LBS.

BOLT GRADES				
U.S.				
Metric				
Steel Type	Low Carbon (soft)	Medium Carbon Heat Treat	Medium Carbon Alloy	Medium Carbon Alloy

SAE	Bolt Grade	2	2	5	5	7	7	8	8	Socket Head Cap Screw	Socket Head Cap Screw
Bolt Dia.	Thread per inch	Dry	Oiled	Dry	Oiled	Dry	Oiled	Dry	Oiled	Dry	Oiled
1/4"	20	4	3	8	6	10	8	12	9	14	11
1/4"	28	6	4	10	7	12	9	14	10	16	13
5/16"	18	9	7	17	13	21	16	25	18	29	23
5/16"	24	12	9	19	14	24	18	29	20	33	26
3/8"	16	16	12	30	23	40	30	45	35	49	39
3/8"	24	22	16	35	25	45	35	50	40	54	44
7/16"	14	24	17	50	35	60	45	70	55	76	61
7/16"	20	34	26	55	40	70	50	80	60	85	68
1/2"	13	38	31	75	55	95	70	110	80	113	90
1/2"	20	52	42	90	65	100	80	120	90	126	100
9/16"	12	52	42	110	80	135	100	150	110	163	130
9/16"	18	71	57	120	90	150	110	170	130	181	144
5/8"	11	98	78	150	110	140	140	220	170	230	184
5/8"	18	115	93	180	130	210	160	240	180	255	204
3/4"	10	157	121	260	200	320	240	380	280	400	320
3/4"	16	180	133	300	220	360	280	420	320	440	350
7/8"	9	210	160	430	320	520	400	600	460	640	510
7/8"	14	230	177	470	360	580	440	660	500	700	560
1"	8	320	240	640	480	800	600	900	680	980	780
1"	12	350	265	710	530	860	666	990	740	1060	845

Per SAE J1701 and SAE J1701M specifications.

METRIC	5.8	8.8	9.8	10.9
Bolt Dia.	Oiled	Oiled	Oiled	Oiled
5mm	3.5	5	6	8
6mm	6	9	10.5	12
8mm	15	22	25	32
10mm	29	44	51	62
12mm	51	76	89	111

UNIVERSAL FRONT DISC BRAKE CHECKLIST

- [] 1) Spindle Properly secured to ball joints and tie rods with castle nut and cotter pin.
- [] 2) All mounting bolts properly tightened.
- [] 3) Wheel bearings properly packed with grease.
- [] 4) Inner bearing must be installed before grease seal.
- [] 5) Rotor / bearings slide onto spindle with ease.
- [] 6) Washer, castle nut properly torqued and cotter pin installed.
- [] 7) Calipers installed and properly torqued.
- [] 8) Spin rotor and check for any interference. (If any interference is found, resolve problem before driving vehicle.)
- [] 9) Flex lines are properly installed with no interference.
- [] 10) Power booster (if applicable) installed properly.
- [] 11) Master cylinder bench bled according to the instructions.
- [] 12) All brake lines are properly tightened and free of leaks.
- [] 13) Turn wheels lock to lock and check for any interference.
- [] 14) Place wheel onto vehicle and spin the wheel to make sure there is no interference between the brakes and wheel.

UNIVERSAL REAR DISC BRAKE CHECKLIST

- [] 1) All bolts on base bracket properly tightened.
- [] 2) All caliper mounting bolts properly tightened.
- [] 3) Rotor slides onto axle with ease.
- [] 4) No interference with rotor and any other parts (splash shield, brackets, etc.).
- [] 5) Caliper is centered over the rotor (because of difference in axle lengths, you may have to shim caliper in or out).
- [] 6) No interference with caliper and rotor.
- [] 7) All brake lines are tight with no leaks.
- [] 8) Parking brake is properly adjusted and not dragging, with vehicle on ground.
- [] 9) Adjustable proportioning valve installed (if applicable).
- [] 10) Distribution block modification made (if applicable).
- [] 11) Brake system properly bled.



WITH EVERY NEW SET OF ROTORS AND PADS, YOU SHOULD GIVE YOUR VEHICLE 200 - 250 MILES OF EASY DRIVING TO PROPERLY SEAT THE PADS TO THE ROTORS. DO NOT TAKE THE VEHICLE UP TO 60 MPH AND JAM ON THE BRAKES BEFORE THE FIRST 200 - 250 MILE BREAK IN PERIOD IS OVER, OR YOU WILL GLAZE THE PADS AND ROTORS.

TECHNICAL SUPPORT / WARRANTY POLICY

You have just purchased a high quality product manufactured by Stainless Steel Brakes Corporation. To ensure proper installation, please read all instructions thoroughly before beginning your work. In most applications, your kit will install as the instructions indicate. From time to time, the original equipment on some vehicles may have slight variations that can effect the ease of installation. Minor modifications during installation may be necessary to successfully install your kit. If modifications are necessary, please refer to a licensed mechanic and/or contact our technicians for modification approval.

Installation of braking, steering and suspension components and systems require proper procedures and methods to assure safe and correct operations.

Always test completed installations in a safe area. For proper operation, and if questionable, correct prior to placing the vehicle in service.

Our company maintains experienced technical service personnel, including a licensed professional engineer who have the knowledge and background to help you with installation or operating problems. Our technicians may be reached by telephone at 716-759-8666, Monday - Friday, 9:30 AM - 5:30PM EST. If unavailable, please leave a brief message, including your day phone number, and they will return your call as soon as possible. You can also e-mail us at tech@ssbrakes.com. If you prefer, we will be pleased to speak with your installing mechanic.

If it becomes necessary to return an item for any reason, a Return Goods Authorization (RGA) Number must first be obtained by telephone. A simple written description of the reason for the return should be included with the part. Your name and phone number should also be included. (Use the attached form.) "Defective" is not enough of a description. See following page for detailed instructions.

We urge you not to disassemble or alter any part supplied, nor purchase additional parts or services in order to facilitate installation. Lack of prior approval by our company will constitute a violation of our warranty with consequent denial of reimbursement for parts - faulty or not.

Before contracting outside professional assistance, please be aware that we do not reimburse for labor charges under any circumstance. Consult our standard warranty card provided with your order.

NEED TO RETURN A PART? FOLLOW THESE INSTRUCTIONS.

- > Did you call our Technical Assistance (716-759-8666) before you decided to make a return? If not, you should do so now.
- > You must have a Return Goods Authorization Number (RGA) issued to you prior to returning any item. If you return without an RGA #, you run the risk of not receiving credit.
- > Make sure to include the completed Return Form with invoice and RGA # with your parts.
- > Whenever possible, please return item in original box with invoice and RGA # clearly marked on the outside of the box.
- > Any return must be shipped postage paid - NO collect shipments will be accepted.
- > All warranty items will be sent ground UPS. Any other type of shipping service will be at customer's expense.

It is a good idea to insure the returned part(s) for the full value to protect yourself against loss. We strongly suggest you ship by UPS or U.S. Mail, no BUS or AIR shipments will be accepted. All foreign returns must have authorization.

NOTE: Under no circumstance should any product(s) or part(s) be returned without prior authorization number (RGA #). Any part which, in our opinion, shows evidence of being used, installed contrary to SSBC instruction, defaced, subjected to improper handling, packaging or shipping by the customer will not be eligible for exchange, refund or warranty consideration.

RETURN FORM

Name: _____

Invoice #: _____

Address: _____

Date Purchased: _____

Purchased From: _____

Phone: _____

List item(s) and a detailed explanation of why you are returning the item(s):

RG A # _____



Use this label for your package.

From: _____ _____ _____	
TO: Stainless Steel Brakes Corp. 11470 Main Road Clarence, NY 14031	
RG A #: _____	Invoice #: _____

REPLACEMENT PADS FOR SSBC PERFORMANCE BRAKE KITS

SSBC Kit #	SSBC Pad #	FMSI #	SSBC Kit #	SSBC Pad #	FMSI #	SSBC Kit #	SSBC Pad #	FMSI #	SSBC Kit #	SSBC Pad #	FMSI #
A120	A1033	D-11	A118	1049	D-204	A123-ADS	1015	D-52	A126-51	1047	D-347
A109AF	10128	D-531	A120-10	10128	D-531	A123DS	1050	D-52	A126-52	10118	D-785
A109AR	10128	D-531	A120-11	10128	D-531	A124	1047	D-347	A126-53	10118	D-785
A109S	1012	D-8	A120-12	10128	D-531	A125	1047	D-347	A126-54	1095	D-731
A110	1049	D-204	A120-13	1095	D-731	A125-1	1047	D-347	A126-55	1095	D-731
A110-11	10113	D-154	A120-14	1095	D-731	A125-1F	1047	D-347	A126-56	1095	D-731
A110-13	1015	D-52	A120-15	1095	D-731	A125-2	1047	D-347	A126-6	1050	D-52
A110-14	10129	D-43	A120-16	1095	D-731	A125-26	10113	D-154	A126-61	1050	D-52
A110-15	1095	D-731	A120-2	10110	D-11	A125-27	10113	D-154	A126-7	1094	D-369
A110-18	1047	D-347	A120-20	A1033	D-11	A125-3	1047	D-347	A126-71	1094	D-369
A110-19	10113	D-154	A120-21	10110	D-11	A125-30	10113	D-154	A126-71A	A1094	D-369
A110-2	1047	D-347	A120-21P	10129	D-43	A125-32	1015	D-52	A126-7A	A1094	D-369
A110-20	10113	D-154	A120-3	10128	D-531	A125-33	10129	D-43	A126-8	1094	D-369
A111	1049	D-204	A120-4	1602891	D-289	A125-34	1095	D-731	A127	1047	D-347
A111-2	1047	D-347	A120-5	1602891	D-289	A125-37	10113	D-154	A127-1	10128	D-531
A111-20	10113	D-154	A120-6	10128	D-531	A125-38	10113	D-154	A127-2	1070	D-413
A111-21	10113	D-154	A120-7A	10128	D-531	A125-39	10113	D-154	A127-3	1071	D-412
A111-24	1015	D-52	A120-7M	10128	D-531	A125-4	1047	D-347	A127-4	10128	D-531
A111-25	10129	D-43	A120-8	10128	D-531	A125-40	1047	D-347	A127-5	10128	D-531
A111-26	1095	D-731	A120-9	10128	D-531	A125-5	1047	D-347	A127-6	1015	D-52
A111-28	1015	D-52	A120D	A1033	D-11	A125-6	1047	D-347	A127-7	1047	D-347
A111-29	10129	D-43	A121	A1033	D-11	A125-7	1047	D-347	A127-8	1015	D-52
A111-3	1047	D-347	A121-1	A1033	D-11	A125-F	1047	D-347	A127-9	1047	D-347
A111-30	1095	D-731	A121-2	A1033	D-11	A126	1070P	D-413	A128	1047	D-347
A111-34	10113	D-154	A121-3	10110	D-11	A126-1	1047	D-347	A128-1	1047	D-347
A111-35	10113	D-154	A121-3P	10110	D-11	A126-10	1015	D-52	A128-2	1047	D-347
A112	1047	D-347	A121-4	10110	D-11	A126-11	1015	D-52	A128-3	1049	D-204
A112-1	1047	D-347	A123	1050	D-52	A126-12	1015	D-52	A128-4	1047	D-347
A112-11	1095	D-731	A123-1	1050	D-52	A126-13	1094A	D-370	A128-5	1049	D-204
A112-12	1095	D-731	A123-14	1095	D-731	A126-14	1094A	D-370	A128-6	1047	D-347
A112-13	10113	D-154	A123-14DS	1095	D-731	A126-15	1094A	D-370	A128-7	1047	D-347
A112-16	1095	D-731	A123-15	10116	D-749	A126-16	1094A	D-370	A129	1050	D-52
A112-17	10133-1	D-784	A123-16	10116	D-749	A126-17	1094A	D-370	A129-1	1050	D-52
A112-19	1095	D-731	A123-18	1095	D-731	A126-18	1015	D-52	A129-10	10128	D-531
A112-2	1047	D-347	A123-1A	1015	D-52	A126-19	1094A	D-370	A129-13	1050	D-52
A112-3	1071	D-412	A123-1ADS	1015	D-52	A126-2	1047	D-347	A129-1A	1015	D-52
A112-4	1047	D-347	A123-1C	1050	D-52	A126-20	1015	D-52	A129-2	1050	D-52
A112-5	1061-1	D199	A123-1DS	1015	D-52	A126-21	10129	D-43	A129-20	10128	D-531
A112-6	10128	D-531	A123-2	1071	D-412	A126-22	10128	D-531	A129-22	1095	D-731
A112-7	1071	D-412	A123-21	A1033	D-11	A126-23	10128	D-531	A129-24	1095	D-731
A112-8	10128	D-531	A123-22	1603681	D-368	A126-24	10128	D-531	A129-25	1050	D-52
A112-93	1047	D-347	A123-23	1603681	D-368	A126-25	10128	D-531	A129-26	1050	D-52
A113	1071	D-412	A123-3	1050	D-52	A126-26	10128	D-531	A129-27	1050	D-52
A113-1	1071	D-412	A123-3A	1015	D-52	A126-27	10128	D-531	A129-28	1050	D-52
A113-10	1071	D-412	A123-3ADS	1015	D-52	A126-28	10128	D-531	A129-29	1050	D-52
A113-12	1095	D-731	A123-3DS	1015	D-52	A126-29	10128	D-531	A129-2A	1015	D-52
A113-13	1095	D-731	A123-4	1050	D-52	A126-3	A1094B	D-369	A129-3	1050	D-52
A113-14	1095	D-731	A123-4A	1015	D-52	A126-30	10128	D-531	A129-30	1015	D-52
A113-15	1095	D-731	A123-4ADS	1015	D-52	A126-31	10128	D-531	A129-31	1015	D-52
A113-16	10113-1	D-784	A123-4DS	1050	D-52	A126-32	1015	D-52	A129-32	1015	D-52
A113-4	10128	D-531	A123-5	1050	D-52	A126-33	10128	D-531	A129-33	1015	D-52
A113-5	1015	D-52	A123-58	1050	D-52	A126-34	10128	D-531	A129-34	1015	D-52
A113-6	10128	D-531	A123-58A	1015	D-52	A126-35	10128	D-531	A129-35	1015	D-52
A113-9	10128	D-531	A123-58ADS	1015	D-52	A126-37	1095	D-731	A129-36	1095	D-731
A114	1047	D-347	A123-58DS	1050	D-52	A126-38	1095	D-731	A129-37	1095	D-731
A115	1047	D-347	A123-59	1050	D-52	A126-39	1095	D-731	A129-38	1095	D-731
A117	1047	D-347	A123-59A	1015	D-52	A126-4	A1094B	D-369	A129-39	1095	D-731
A117-1	1047	D-347	A123-59ADS	1015	D-52	A126-40	10126	D-834	A129-3A	1015	D-52
A117-12	1095	D-731	A123-5A	1015	D-52	A126-41	10126	D-834	A129-4	1050	D-52
A117-14	10113	D-154	A123-5ADS	1015	D-52	A126-42	10118(F) 160834®	D-785(F) D-834®	A129-40	1095	D-731
A117-2	1047	D-347	A123-5DS	1050	D-52	A126-43	10118(F) 10119(R)	D-785(F) D-792(R)	A129-41	1095	D-731
A117-3	1071	D-412	A123-6	1071	D-412	A126-44	10118(F) 10143(R)	D-785(F) D-974A(R)	A129-4A	1015	D-52
A117-4	1071	D-412	A123-7	10128	D-531	A126-46	10126	D-834	A129-6	10128	D-531
A117-5	10128	D-531	A123-7DS	10128	D-531	A126-47	1610921	D-1092	A129-8	10128	D-531
A117-6	10128	D-531	A123-8	10128	D-531	A126-48	1095	D-731	A129-A	1015	D-52
A117-7	10128	D-531	A123-9	10128	D-531	A126-5	1047	D-347	A130	1047	D-347
A117-9	1095	D-731	A123-A	1015	D-52	A126-50	10113	D-154	A130-1	1047	D-347

***RE-ORDER PADS DIRECTLY FROM SSBC**



VISIT OUR NEW WEBSITE AT...

SSBRAKES.COM

REPLACEMENT PADS FOR SSBC PERFORMANCE BRAKE KITS

SSBC Kit #	SSBC Pad #	FMSI #	SSBC Kit #	SSBC Pad #	FMSI #	SSBC Kit #	SSBC Pad #	FMSI #	SSBC Kit #	SSBC Pad #	FMSI #
A130-2	1047	D-347	A148-6FE	10129	D-43	A164-13	10129	D-43	A182	10113	D-154
A132-1	1046	D-34	A148-6GE	10129	D-43	A164-14	10128	D-531	A185-M	1015	D-52
A132-2	1095	D-731	A148-7FE	10129	D-43	A164-16	10128	D-531	A185-S	1015	D-52
A132-A	1046	D-34	A148-7GE	10129	D-43	A164-2	10128	D-531	A186-1	A1094	D-11
A132-M	1046	D-34	A148-A	10113	D-154	A164-3	10128	D-531	A187	1095	D-731
A133	1046	D-34	A150	1047	D-347	A164-4	10128	D-531	A187-1	1095	D-731
A133-1	1046	D-34	A150-2	1047	D-347	A164-5	10128	D-531	A187-2	10126	D-834
A133-10	A1033	D-11	A151	1071	D-412	A164-6	10128	D-531	A187-3	10126	D-834
A133-11	10110	D-11	A152	A1033	D-11	A164-7	10128	D-531	A187-4	10133-1	D-784
A133-11O	10129	D-43	A152-1	10110	D-11	A164-8	10128	D-531	A187-5	1095	D-731
A133-2	A1033	D-11	A153	A1033	D-11	A164-9	10128	D-531	A187-6	1095	D-731
A133-3	10110	D-11	A153-1	A1033	D-11	A165	10128	D-531	A188	10110	D-11
A133-4	1095	D-731	A153-2	10110	D-11	A165-1	10128	D-531	A188-1	10110	D-11
A133-5	1095	D-731	A153-3	10110	D-11	A165-2	1095	D-731	A189	10110	D-11
A133-6	1095	D-731	A153-4	1095	D-731	A165-3	1095	D-731	A189-1	1095	D-731
A134	1046	D-34	A153-5	1095	D-731	A166-1	1015	D-52	A189-2	1095	D-731
A134-1	1046	D-34	A154	A1033	D-11	A166-13	1015	D-52	A193	1095	D-731
A134-10	A1033	D-11	A154-1	A1033	D-11	A166-14	1015	D-52	A193-1	10133-1	D-784
A134-3	1095	D-731	A154-2	10110	D-11	A166-15	10128	D-531	A193-2	10118	D-785
A135-1	1094A	D-370	A154-3	10110	D-11	A166-16	1015	D-52	A194	1097	D-614
A135-1A	A1094	D-369	A154-4	A1033	D-11	A166-17	1015	D-52	A195	A10129	D-43
A135-2	1094	D-369	A154-5	A1033	D-11	A166-18	10128	D-531	A195-1	A10129	D-43
A135-3	10110	D-11	A154-6	1095	D-731	A166-19	1015	D-52	A195-2	A10129	D-43
A136	1047	D-347	A155	1047	D-347	A166-1A	1015	D-52	A196	A10129	D-43
A136-1	1047	D-347	A155-1	1047	D-347	A166-2	10128	D-531	A196-1	A10129	D-43
A137	1012	D-8	A155-2	1047	D-347	A166-20	1015	D-52	A196-2	A10129	D-43
A137-1	1050	D-52	A155-3	10113	D-154	A166-22	1047	D-347	A197	A10129	D-43
A137-1A	1015	D-52	A155-4	10113	D-154	A166-23	A1015-3	D-11	A197-1	A10129	D-43
A137-2	10128	D-531	A156	A1033	D-11	A166-24	1015	D-52	A197-2	A10129	D-43
A137-3	1050	D-52	A156-1	A1033	D-11	A166-25	1047	D-347	A198	10129	D-43
A137-3A	1015	D-52	A156-2	10110	D-11	A166-26	1047	D-347	A198-1	10129	D-43
A138-2	1050	D-52	A156-3	10110	D-11	A166-3	1015	D-52	A199	10129	D-43
A138-A	10113	D-154	A156-4	1095	D-731	A166-3A	1015	D-52	A199-1	10129	D-43
A140	1084-2	D-154	A156-5	1095	D-731	A166-4	10128	D-531	A200	10129	D-43
A140-1	10128	D-531	A157	1047	D-347	A166-5	1015	D-52	A200-1	10129	D-43
A142	1050	D-52	A158	1047	D-347	A166-6	1015	D-52	A22171	A10129	D-43
A142-1	1071	D-412	A158-1	1047	D-347	A166-7	1015	D-52	A22171-1	A10129	D-43
A144	1084-2	D-154	A158-2	1094A	D-370	A166-8	1015	D-52	A22171-2	A10129	D-43
A144-1	1071	D-412	A158-3	1094A	D-370	A166-9	10128	D-531	A22172	A10129	D-43
A145	1084-2	D-154	A158-4	10128	D-531	A167	1015	D-52	A22172-1	A10129	D-43
A145-1	1071	D-412	A158-5	1095	D-731	A167-1	1015	D-52	A22172-2	A10129	D-43
A146	1071	D-412	A159	10100	D-268	A167-2	10128	D-531	A22173	A10129	D-43
A146-1	1084-2	D-154	A159-1	1094A	D-370	A167-3	1015	D-52	A22173-1	A10129	D-43
A148	1084-2	D-154	A160-1	1047	D-347	A167-4	1015	D-52	A22173-2	A10129	D-43
A148-1	1084-2	D-154	A160-2	1015	D-52	A167-5	10128	D-531	A2350000	10112	D-8
A148-14	1050	D-52	A160-3	1015	D-52	A168	1015	D-52	A2350001	1015	D-52
A148-14A	1015	D-52	A160-4	1047	D-347	A168-1	1015	D-52	A2350002	1015	D-52
A148-15	1050	D-52	A161	1015	D-52	A168-12	1095	D-731	A2350003	10113	D-154
A148-15A	1015	D-52	A161-1	1047	D-347	A168-2	10128	D-531	A2350004	1099(F) 1070(R)	D-623(F) D-413(R)
A148-16	1050	D-52	A161-2	1015	D-52	A168-3	1015	D-52	A2350004R	1070	D-413
A148-16A	1015	D-52	A162	1095	D-731	A168-4	1015	D-52	A2350005	10101(F) 10102(R)	D-294(F) D-295(R)
A148-17	1050	D-52	A162-1	10113	D-154	A168-5	10128	D-531	A2350006	1081(F) 1070(R)	D-412 (F) D-413(R)
A148-17A	1015	D-52	A163	1015	D-52	A168-6	1015	D-52	A2350007	1081(F) 1070(R)	D-412 (F) D-413(R)
A148-18	1050	D-52	A163-1	1047	D-347	A168-7	1015	D-52	A2350008	1095(F) 1096(R)	D-731(F) D-732(R)
A148-18A	1015	D-52	A163-2	1015	D-52	A168-8	10128	D-531	A2350008R	1096	D-732
A148-1A	10113	D-154	A163-3	1015	D-52	A170	1015	D-52	A2350009	1097(F) 1098(R)	D-614(F) D-628(R)
A148-2	A1033	D-11	A163-4	1047	D-347	A170-1	10128	D-531	A2350009R	1097(F) 1098(R)	D-614(F) D-628(R)
A148-28	10128	D-531	A163-5	1015	D-52	A171	1015	D-52	A2350010	1015	D-52
A148-29	10128	D-531	A163-6	10113	D-154	A171-1	1015	D-52	A2350012	1015	D-52
A148-30	10110	D-11	A163-7	10113	D-154	A171-2	10128	D-531	A2350013	1081	D-412
A148-30E	10129	D-43	A163-8	10113	D-154	A171-3	1047	D-347	A2350014	10116	D-749
A148-31	1084-2	D-154	A163-9	10113	D-154	A172	1015	D-52	A2350014R	10117	D-750
A148-32	1084-2	D-154	A164	10128	D-531	A172-1	1015	D-52	A2351000	1015	D-52
A148-32A	10113	D-154	A164-1	10128	D-531	A174-1	1015	D-52	A2351001	1015	D-52
A148-33	1095	D-731	A164-10	10128	D-531	A180-M	1015	D-52	A2351002	1015	D-52
A148-34	1095	D-731	A164-11	10128	D-531	A180-S	1015	D-52	A2351003	10100	D-368
A148-4E	10129	D-43	A164-12	10128	D-531	A181	10113	D-154	A2351004	1094	D-369

***RE-ORDER PADS DIRECTLY FROM SSBC**

REPLACEMENT PADS FOR SSBC PERFORMANCE BRAKE KITS

SSBC Kit #	SSBC Pad #	FMSI #	SSBC Kit #	SSBC Pad #	FMSI #	SSBC Kit #	SSBC Pad #	FMSI #
A2351005	1094	D-369	A2370008	10111	D-529	W125-37	10113	D-154
A2351006	1094	D-369	A2370009	10111	D-529	W125-38	10113	D-154
A2351007	1015	D-52	A2370010	10111	D-529	W125-39	10113	D-154
A2351008	10100	D-368	A2370011	10114	D-746	W129	1050	D-52
A2351009	1094	D-369	A2370012	10120	D-820	W129-2	1050	D-52
A2351010	1094	D-369	A2370013	10125	D-702	W129-22	1095	D-731
A2351011	1015	D-52	A2370014	10125	D-702	W129-24	1050	D-52
A2351012	1094	D-369	A2370015	1093(F) 10139(R)	D-477(F) D-666(R)	W129-26	1050	D-52
A2351013	1015	D-52	A2370016	10140(F) 10141(R)	D-790(F) D-791(R)	W129-28	1050	D-52
A2351014	1094	D-369	A2370017	10142(F) 10141(R)	D-945(F) D-791(R)	W129-2A	1015	D-52
A2351015	1015	D-52	A2380001	10121(F) 10122(R)	D-591(F) D-512(R)	W129-3	1050	D-52
A2351016	1094	D-369	A2380002	10123(F) 10124(R)	D-592(F) D-592(R)	W129-30	1015	D-52
A2351017	10113	D-154	W110-11	10113	D-154	W129-32	1015	D-52
A2351018	10113	D-154	W110-2	1047	D-347	W129-34	1015	D-52
A2351019	10118(F) 10119(R)	D-785(F) D-792(R)	W110-20	10113	D-154	W129-36	1095	D-731
A2351020	10126	D-834	W111-2	1047	D-347	W129-38	1095	D-731
A2351021	10119	D-792	W111-20	10113	D-154	W129-3A	1015	D-52
A2351022	10118	D-785	W111-21	10113	D-154	W129-40	1095	D-731
A2351023	10113	D-154	W111-3	1047	D-347	W129-A	1015	D-52
A2351024	10133-1	D-784	W111-34	10113	D-154	W132	1046	D-347
A2351025	10118(F) 10143(R)	D-785(F) D-974A(R)	W111-35	10113	D-154	W132-2	1095	D-731
A2351026	10143	D-974A	W120	A1033	D-11	W132-3	10129	D-43
A2351027	10133-1(F) 10134(R)	D-784(F) D-785(R)	W120-13	1095	D-731	W132-4	10129	D-43
A2351028	10133-1	D-784	W120-2	A1033	D-11	W133-2	A1033	D-11
A2360000	A1033	D-11	W120-22	10129	D-43	W133-3	A1033	D-11
A2360001	1046	D-34	W120-23	10129	D-43	W133-4	1095	D-731
A2360002	1046	D-34	W120-4	1602891	D-289	W133-5	1095	D-731
A2360003	1066	D-237	W123	1050	D-52	W148-35	10129	D-43
A2360004	1061(F) 1049(R)	D-199(F) D-204(R)	W123-14	1095	D-731	W148-36	10129	D-43
A2360005	1061	D-199	W123-14DS	1095	D-731	W153	A1033	D-11
A2360006	10103(F) 10104(R)	D-600(F) D-627(R)	W123-24	10129	D-43	W153-2	A1033	D-11
A2360007	1081(F) 10145(R)	D-412(F) D-627A(R)	W123-25	10129	D-43	W153-4	1095	D-731
A2360008	1061-1(F) 1047(R)	D-199(F) D-347(R)	W123-3	1050	D-52	W153-6	10129	D-43
A2360009	10127	D-711	W123-3A	1015	D-52	W153-7	10129	D-43
A2360010	10127	D-711	W123-3ADS	1015	D-52	W154	A1033	D-11
A2360011	10137(F) 10104(R)	D-491(F) D-627(R)	W123-3DS	1050	D-52	W154-2	A1033	D-11
A2361001	10146(F) 10147(R)	D-749(F) D-1012(R)	W123-A	1015	D-52	W154-7	10129	D-43
A2361002	10146(F) 10147(R)	D-749(F) D-1012(R)	W123-ADS	1015	D-52	W154-8	10129	D-43
A2361003	10147	D-1012	W123DS	1050	D-52	W155	1047	D-347
A2370000	1092	D-203	W125	1047	D-347	W155-3	10113	D-154
A2370001	1092	D-203	W125-1	1047	D-347	W156	A1033	D-11
A2370002	1093	D-477	W125-2	1047	D-347	W156-2	A1033	D-11
A2370003	1015	D-52	W125-26	10113	D-154	W156-4	1095	D-731
A2370005	10111	D-529	W125-27	10113	D-154	W156-6	10129	D-43
A2370006	1094	D-369	W125-3	1047	D-347	W156-7	10129	D-43
A2370007	1094	D-369	W125-30	10113	D-154			

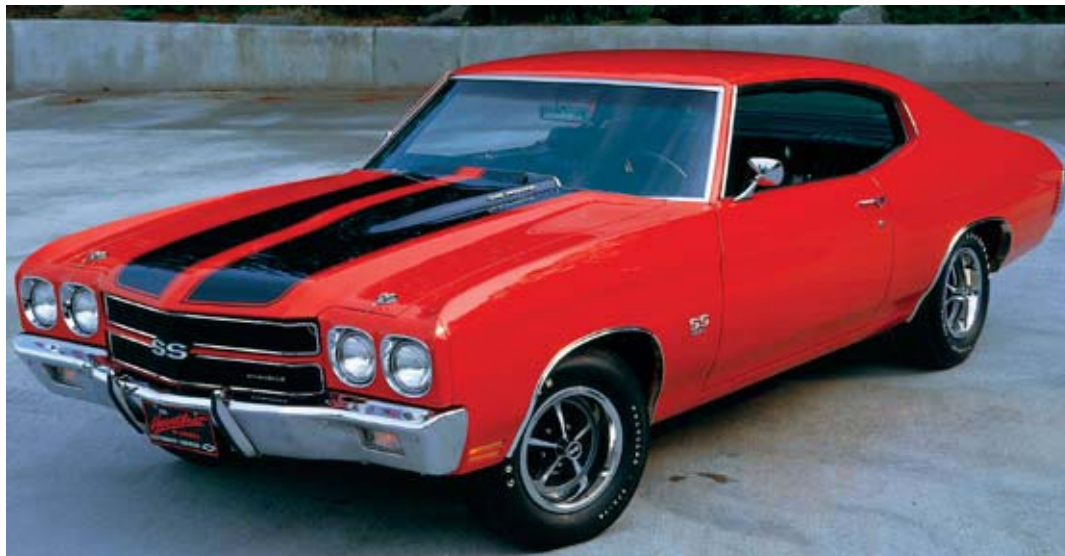

***RE-ORDER PADS DIRECTLY FROM SSBC ALL PART NUMBERS ARE SUBJECT TO CHANGE WITHOUT NOTICE.**



VISIT OUR NEW WEBSITE AT...

SSBRAKES.COM