

DIRECTION 907

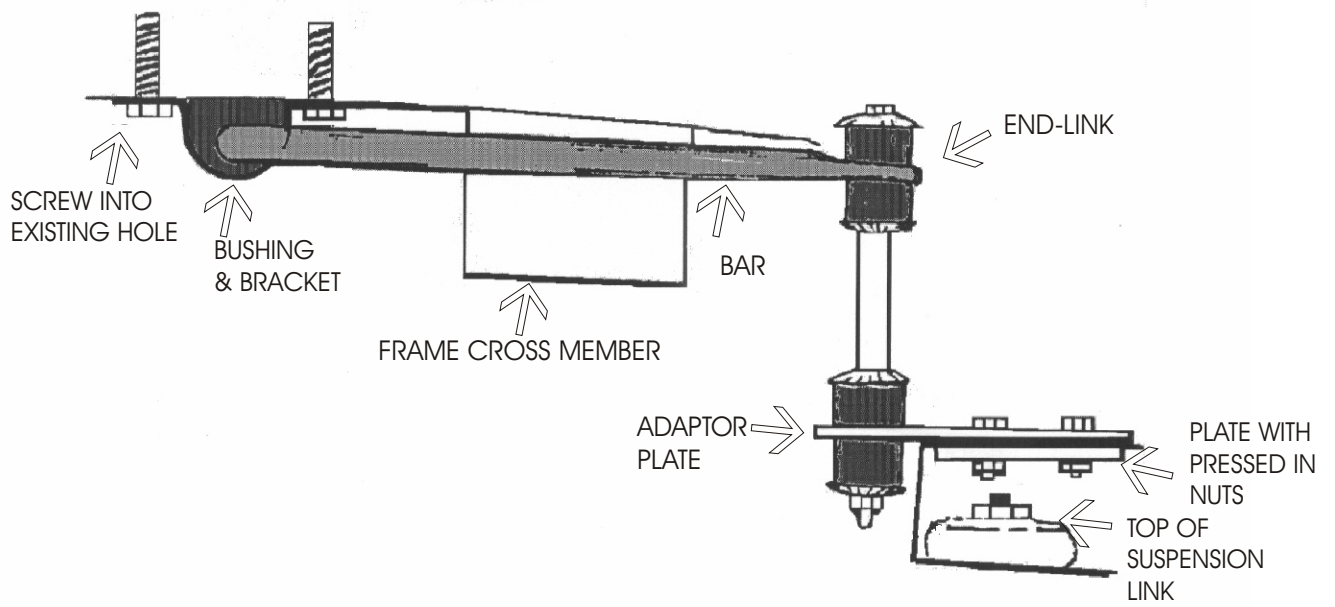

HOW TO INSTALL A #402 U-BOLT

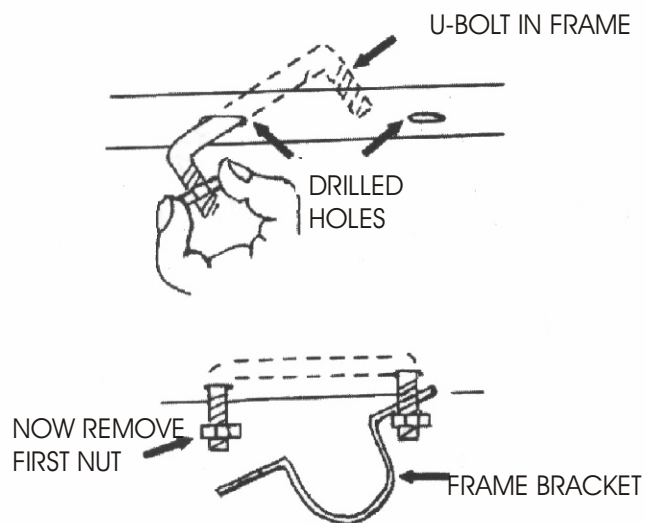

DIRECTION #907

- STEP #1.** Slide bar into position from one side so it passes just over the spare tire, arms forward. Slide the large bushing onto the bar.
- STEP #2.** Assemble end link on bar end as shown with the adaptor plate at the bottom. Tighten the lock nuts only enough to keep the assembly snug.
- STEP #3.** Slide the plate with the two pressed in lock nut into the suspension assemble snug. Run the 5/16" bolts through the adaptor plate, then through the existing holes in the suspension into the plate containing the lock nuts.
- STEP #4.** Position frame bracket over bar bushing and attach to existing threaded holes via bolts provided. Note: Very early models and late models have no threaded holes in the frame. On these bars use the square U-bolt provided- see general instruction.
- STEP #5.** Check all fastenings for suitable tightness and make sure that all parts clear throughout the suspension travel.
- STEP #6.** Road test the car and accustom yourself to your cars new handling. As we cannot supervise your installation (or your driving) we cannot be held responsible for more than the cost of the kit. Note: for best results also install our front bar.

KIT CONTAINS:

2 RH 015 End-links	4 RH 304 Nuts
2 RH 040 Brackets	2 RH 508 Bushings
2 RH 402 U-Bolts	4 RH 104 Washers
2 RH 609 Adaptor Plates	2 RH 610 Adaptor Plates
4 RH 200 Bolts	4 RH 218 Bolts