

DIRECTION 935

BAR DETAIL MOUNT

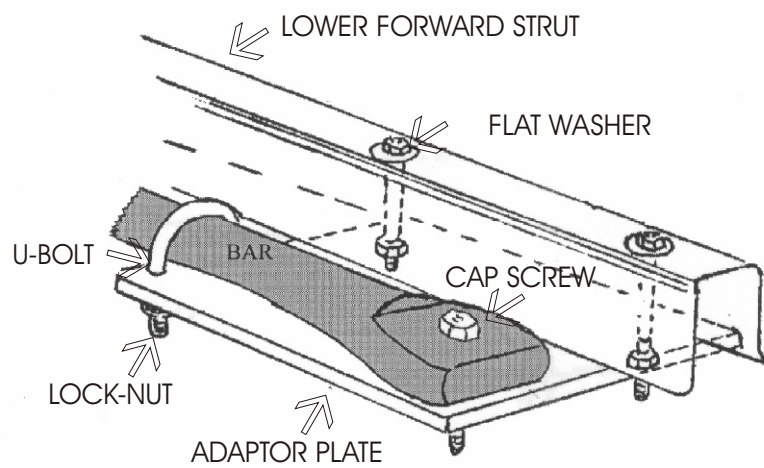

BAR ASSEMBLY ILLUSTRATION

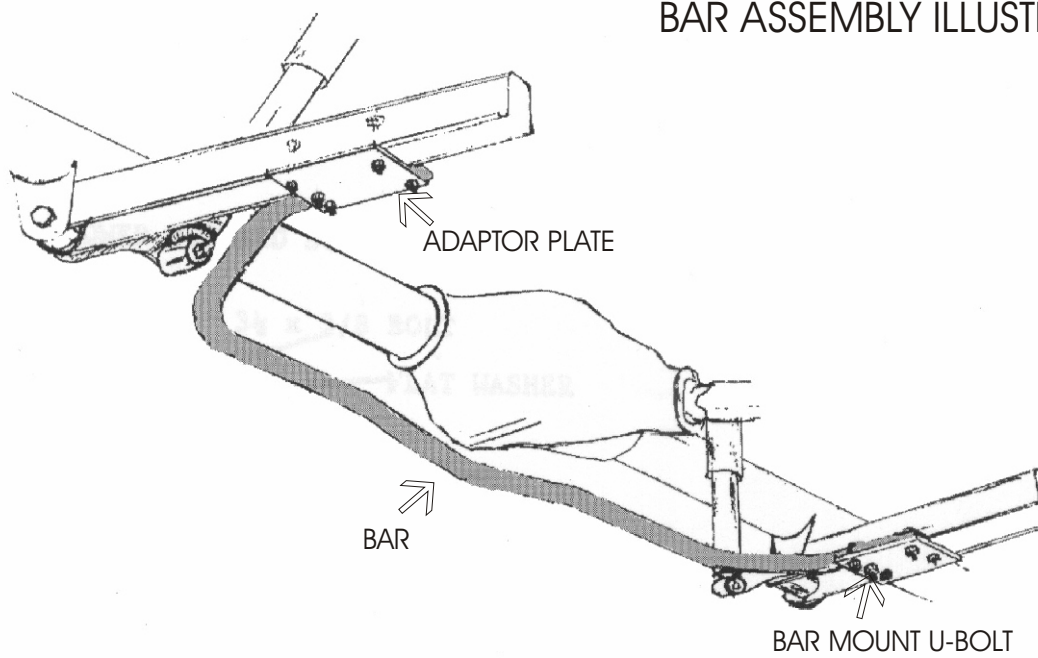

DIRECTION #935

- STEP #1.** **Attach the sway bar to the reinforcing plate using the short bolt and U-bolts. The U-bolt may need to be bent slightly to fit the plates. This should be checked first for ease of assembly.**
- STEP #2.** **With plate attached to the bar it should be held up under the car in position. As the lower suspension struts are parallel, the bar can be moved fore and aft to obtain proper clearance of differential carrier and tail pipe. Bar should be located far enough to the rear so the rising portion of tailpipe will just clear it as car is depressed on its springs. At this point bar will also just clear under the differential without reducing road clearance.**
- STEP #3.** **With the bar in position against the bottom of the lower suspension strut, mark it for drilling.**
- STEP #4.** **Drill the strut with a 3/8" drill bit and bolt the sway bar on. The dip should be down.**
- STEP #5.** **Have someone bounce the rear of the car while you check movement of all parts to be sure that no part of the kit can contact exhaust, shock, gas tank, differential etc. If all is clear throughout the suspension travel of the rear suspension, tighten all nuts.**
- STEP #6.** **Road test the car and familiarize yourself with your car's new handling. As we cannot supervise your installation (or driving) we cannot be held responsible for more than the cost of the kit.**

KIT INCLUDES:

2	RH 039	Plates
2	RH 400	U-Bolts
4	RH 102	Washers
4	RH 205	Bolts
10	RH 304	Lock-Nuts
2	RH 213	Bolts