

- Step 1.** Place the U-bolts around the axle. Be sure they are passed under the brake line so as not to pinch them. Raise up the slotted plate under the U-bolts to engage the U-bolt legs. Follow with the bar bracket around the bar. Start the nuts. Place the mid-section bushing on the bar near the bends with the flat side up. Nest, slide the loosely assembled U-bolt and bracket assembly down the axle so that the bracket is around the rubber bushing. Inset the locking device from one side with the legs toward the axle. Center it on the slotted plate. The bar dip should be under the differential with the arms forward.
- Step 2.** Assemble the end-link as illustrated. Be sure that the washers have their cupped or hollow side towards the rubber bushing and that the bushings have the end with the stepped surface towards the bracket or bar eye. Tighten the lock-nut so the assembly is snug, but not so tight that the bushing bulge to a noticeable extent.
- Step 3.** Position the bar so that the gorges are horizontal and the axle clamp assembly holding the bar mid-section is below the axle. With the car resting naturally on its springs on level ground, the frame brackets should position themselves in alignment with the frame bottom. Adjust the bar position relative to the axle if needed.
- Step 4.** Mark through the frame bracket holes. Drill one hole with a 3/8" drill bit. Use the square U-bolt to get the exact spacing for the second hole and drill it.
- Step 5.** Place a lock-nut on one leg of the square U-bolt. Insert the other end into one drilled hole. Maneuver it until it reappears through the other drilled hole. Place one end of the frame bracket over the U-bolt leg and replace the nut.
- Step 6.** Have some bounce the rear of the car so you can check that all parts of the bar and hardware clear throughout the suspension travel distance. If all is clear, tighten the nuts on the frame and axle.
- Step 7.** Road test the car to familiarize yourself with its new handling. As we cannot supervise your installation or your driving, we cannot be responsible for more than the cost of the kit.

Hardware

- | | |
|---------------------------|----------------------|
| 2 RH 402 Square U-Bolts | 2 RH 044 Brackets |
| 2 RH 015 End-Links | 2 RH 405 U-Bolts |
| 2 RH 054 Channel Brackets | 2 RH 031 Base Plates |
| 2 RH 508 Bushings | 2 RH 043 Brackets |
| 8 RH 304 Lock-Nuts | |

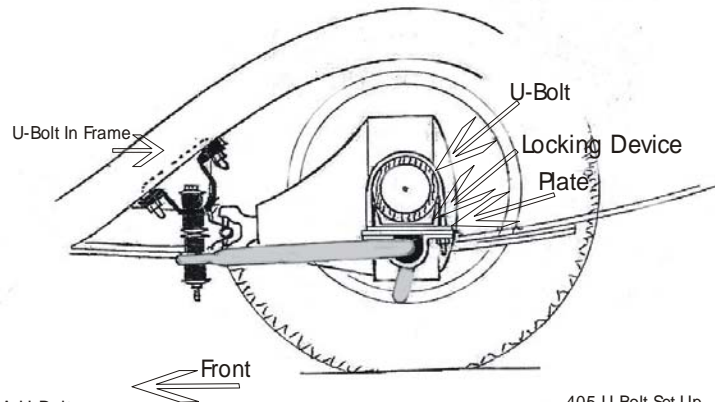

How To Install A U-Bolt

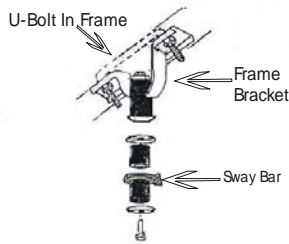
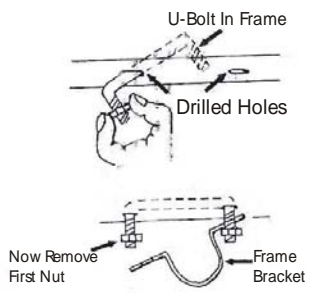

405 U-Bolt Set Up

